

SIGNETICS LOW COST CLOCK GENERATOR CIRCUITS MP52

AN APPLICATIONS MEMO

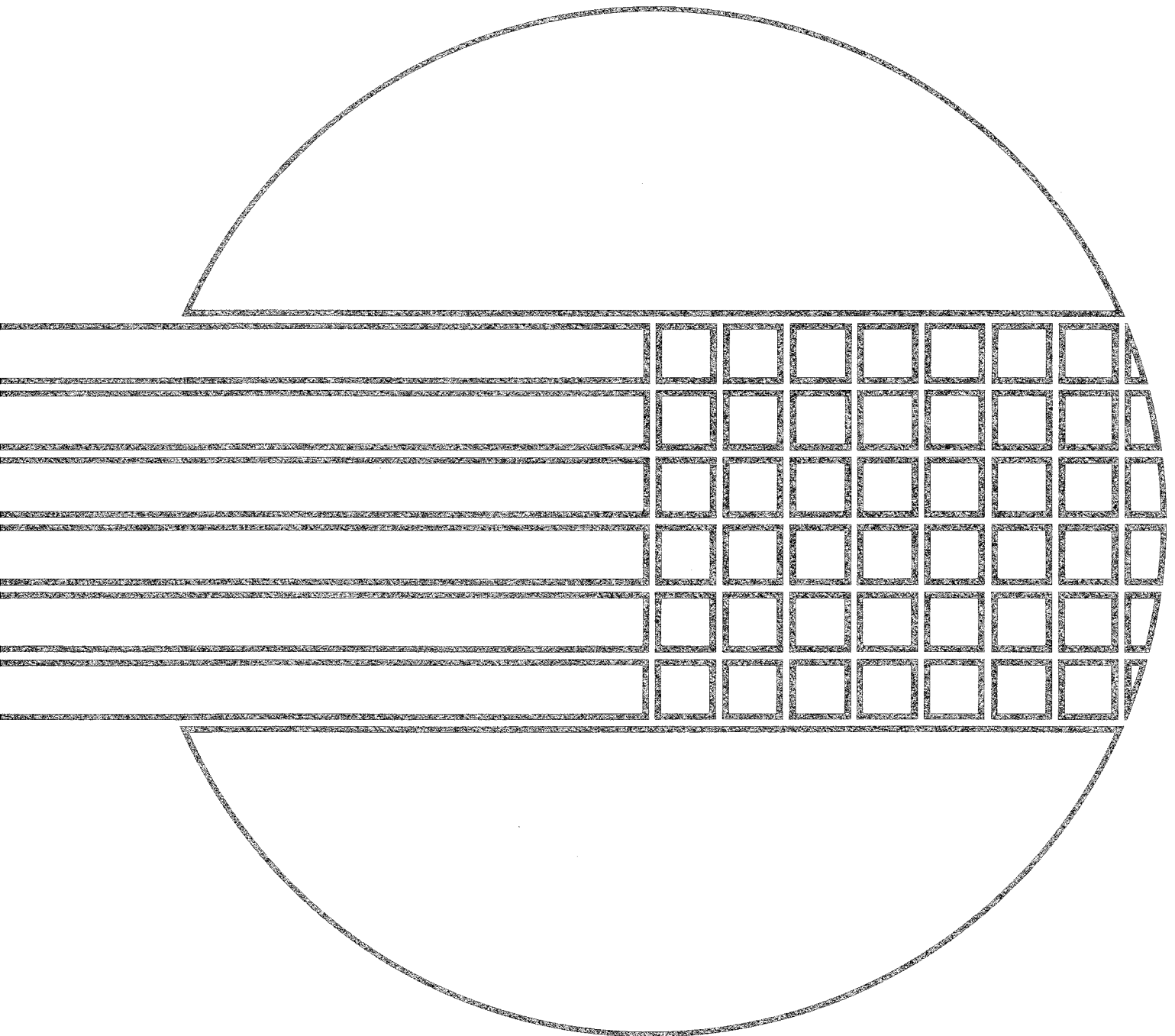

2650 MICROPROCESSOR APPLICATIONS MEMO

GENERAL

The clock circuit requirements for microprocessors range from tightly specified, two-phase, non-overlapping types to simple single-phase, TTL compatible types. To lower system cost, the Signetics 2650 Microprocessor was designed to operate with a single-phase, TTL-level clock without any special clock driver circuitry. The clock input specifications for the 2650 are summarized in Table I.

This Applications Memo describes several clock generator circuits that may be used with the 2650. These circuits use standard TTL logic elements (7400 series). They include RC, LC, and crystal oscillator type circuits.

The stability required by the user's application will determine the type of clock generator that should be used. Tables showing the measured frequencies at several temperatures and supply voltages are presented.

RC OSCILLATOR

A circuit diagram of an RC oscillator is given in Figure 1.

The first inverter is biased into its linear region by resistor R. The positive feedback capacitor (C) from node (B) to node (A) causes the circuit to oscillate. The third inverter acts as a buffer to drive the clock input of the 2650. The oscillation period is approximately equal to $3RC$. Measurements taken on this circuit showed a 10 ns rise time and a 7 ns fall time.

Table II shows how the frequency of the RC oscillator is affected by variations in V_{CC} and ambient temperature.

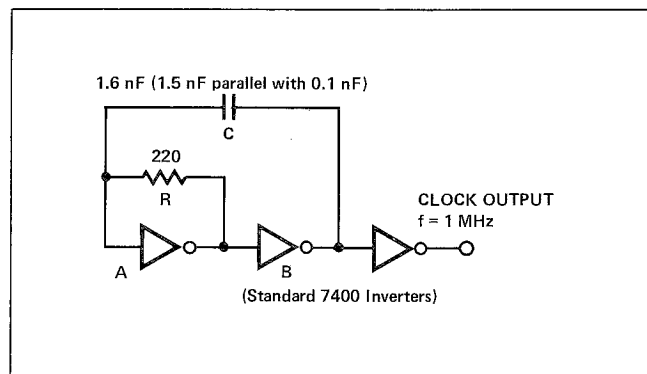

FIGURE 1. RC Clock Generator

TABLE I
2650 CLOCK INPUT SPECIFICATIONS

SYMBOL	PARAMETER	TEST CONDITIONS	LIMITS		UNIT
			MIN.	MAX.	
I_{LI}	Input Load Current	$V_{IN} = 0$ to 5.25V		10	μA
V_{IL}	Input Low Voltage		-0.6	0.8	V
V_{IH}	Input High Voltage		2.2	V_{CC}	V
C_{IN}	Input Capacitance	$V_{IN} = 0V$		10	pF
t_{CH}	Clock High Phase		400	10,000	nsec
t_{CL}	Clock Low Phase		400	∞	nsec
t_{CP}	Clock Period		800	∞	nsec
t_r	Clock Rise Time			20	nsec
t_f	Clock Fall Time			20	nsec

Timing Reference = 1.5V

$T_A = 0^\circ$ to $70^\circ C$

$V_{CC} = 5V \pm 5\%$

TABLE II
RC OSCILLATOR STABILITY
Ambient Temperature (T_A)

	0°C	25°C	70°C	Stability T^* ($V_{CC} = \text{constant}$)
$V_{CC} = 4.75V$	1044.50 KHz	1028.95 KHz	998.50 KHz	+1.51%, -2.96%
$V_{CC} = 5.0V$	1043.20 KHz	1023.65 KHz	990.45 KHz	+1.91%, -3.24%
$V_{CC} = 5.25V$	1038.80 KHz	1013.63 KHz	979.65 KHz	+2.48%, -3.35%
Stability V^{**} ($T_A = \text{constant}$)	+0.12% -0.42%	+0.52% -0.98%	+0.20% -1.1%	

*Stability T with respect to $T_A = 25^\circ C$
**Stability V with respect to $V_{CC} = 5.0V$

A second type of RC oscillator uses a monostable multi-vibrator circuit (N74123) as illustrated in Figure 2. The pulse width of each monostable is determined by the external resistor and capacitor:

$$t_w = (0.28) (R_{ext}) (C_{ext}) \left(1 + \frac{0.7}{R_{ext}}\right)$$

where

R_{ext} is in $K\Omega$

C_{ext} is in pF,

and

t_w is in ns.

In this circuit, the oscillation is caused by the triggering of each monostable by the other one. The oscillation frequency can be derived from the following equation:

$$f_{osc} = \frac{1}{t_{w1} + t_{w2}}$$

where:

t_{w1} is the pulse width of the first monostable, and
 t_{w2} is the pulse width of the second monostable.

Measurements on frequency stability with a load of one TTL input are presented in Table III.

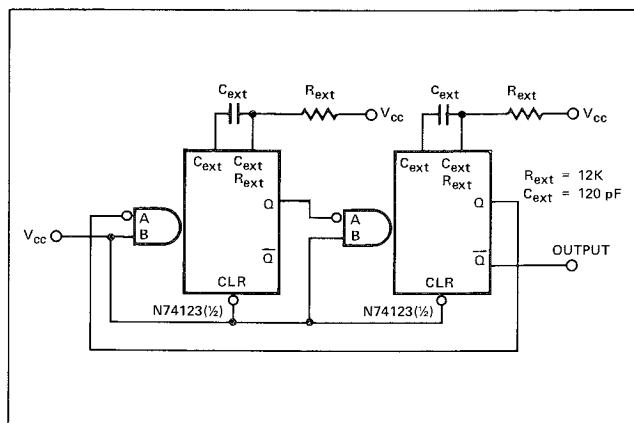

FIGURE 2. RC Clock Generator with Monostable Circuit N74123

TABLE III
MONOSTABLE MULTIVIBRATOR OSCILLATOR
STABILITY

Ambient Temperature (T_A)

	0°C	25°C	70°C	Stability T^* ($V_{CC} = \text{constant}$)
$V_{CC} = 4.75V$	1063.65 KHz	1046.72 KHz	1041.16 KHz	+1.62%, -0.53%
$V_{CC} = 5.0V$	1063.80 KHz	1042.83 KHz	1032.63 KHz	+2.01%, -0.98%
$V_{CC} = 5.25V$	1063.80 KHz	1039.95 KHz	1024.02 KHz	+2.29%, -1.53%
Stability V^{**} ($T_A = \text{constant}$)	+0.00% -0.014%	+0.276% -0.373%	+0.826% -0.833%	

*Stability T with respect to $T_A = 25^\circ C$
**Stability V with respect to $V_{CC} = 5.0V$

The observed rise and fall times at the output of this circuit were 10 ns and 8 ns, respectively. The stability of this circuit reflected a slight improvement over the stability of the RC oscillator shown in Figure 1.

LC OSCILLATOR

Figure 3 shows an LC oscillator circuit using standard TTL inverters.

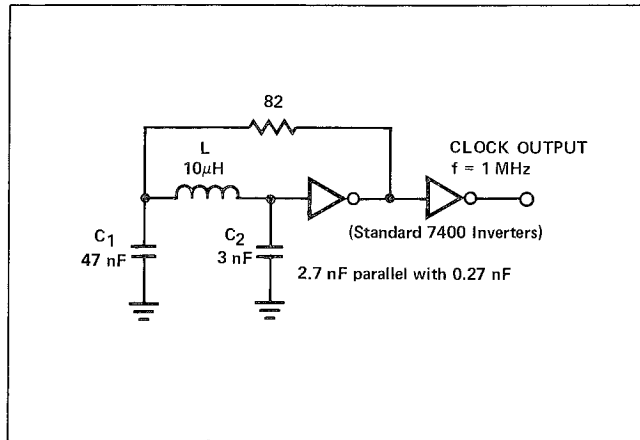

FIGURE 3. LC Clock Generator

The first inverter combined with the passive components forms a Colpitts oscillator. The resistor provides a feedback path for the first inverter and forces it into its linear region.

The second inverter "squares" the oscillator signal and provides an output buffer. The oscillator frequency can be derived from the following equation:

$$f_{osc} = \frac{1}{2\pi \sqrt{L} \left[\frac{(C1) \cdot (C2)}{(C1) + (C2)} \right]}$$

Measurements from the circuit in Figure 3 showed a 10 ns rise time and a 7 ns fall time. Measurements on frequency stability are provided in Table IV.

CRYSTAL OSCILLATORS

In 2650 Microprocessor applications requiring a highly stable clock, a crystal oscillator may be required. Some examples of crystal oscillator circuits are shown in Figures 4 and 5. The circuit shown in Figure 4 uses a 1.025 MHz crystal while the circuit shown in Figure 5 uses a low cost 4.433618 MHz crystal commonly found in European manufactured color TV sets. The output of the oscillator is divided by four to obtain a clock frequency of 1.1 MHz.

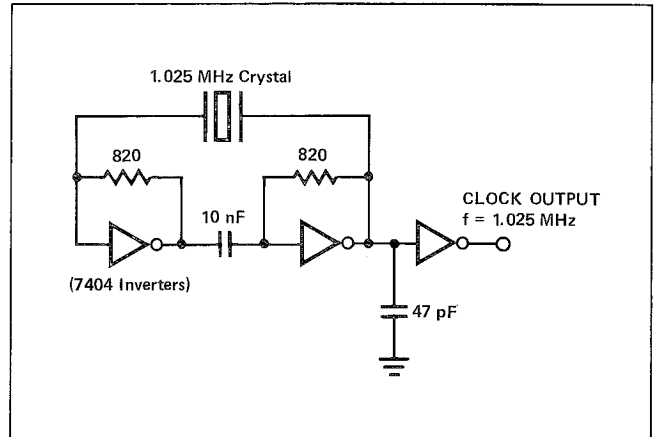

FIGURE 4. Clock Generator Using a Non-TV Standard Crystal

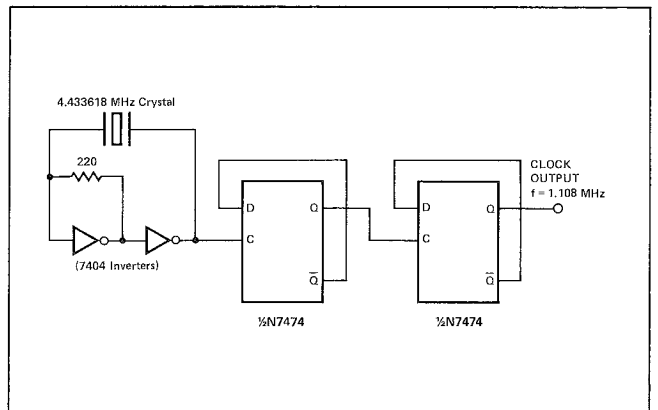

FIGURE 5. Low Cost Color TV Crystal Clock Generator

TABLE IV
LC OSCILLATOR STABILITY
Ambient Temperature (T_A)

	0°C	25°C	70°C	Stability* (V _{CC} = constant)
V _{CC} = 4.75V	1027.14 KHz	1017.75 KHz	1004.46 KHz	+0.92%, -1.31%
V _{CC} = 5.0V	1026.62 KHz	1016.99 KHz	1004.11 KHz	+0.95%, -1.26%
V _{CC} = 5.25V	1025.82 KHz	1016.30 KHz	1003.73 KHz	+0.94%, -1.24%
Stability** (T _A = constant)	+0.05% -0.08%	+0.07% -0.07%	+0.03% -0.04%	

*Stability_T with respect to T_A = 25°C
**Stability_V with respect to V_{CC} = 5.0V

The circuit of Figure 5 can also be used with a 3.5795 MHz United States color TV crystal to provide an output frequency of 895 KHz.

The stability of the crystal oscillator circuits is mainly determined by the stability of the crystal used. The circuits shown in Figures 4 and 5 had a stability of 0.003% over the 0°C to 70°C temperature range and 0.002% over a variation of power supply voltage from 4.75V to 5.25V.

SUMMARY

Table V is a summary of the stability measurements made for the oscillator circuits described in this application note. As the table shows, the crystal circuits exhibit great stability relative to the RC and LC oscillators, but they suffer the added expense of the crystal. Any of the oscillator circuits shown in this application note can be used to drive the 2650 microprocessor clock input.

**TABLE V
SUMMARY OF OSCILLATOR STABILITY**

CIRCUIT TYPE	STABILITY					
	(4.75V to 5.25V)			(0°C to 70°C)		
	0°C	25°C	70°C	4.75V	5.0V	5.25V
RC	+0.12% -0.42%	+0.52% -0.98%	+0.2% -1.1%	+1.51% -2.96%	+1.91% -3.24%	+2.48% -3.35%
RC MONO-STABLE	+0.00% -0.014%	+0.276% -0.373%	+0.826% -0.833%	+1.62% -0.53%	+2.01% -0.98%	+2.29% -1.53%
LC	+0.05% -0.08%	+0.07% -0.07%	+0.03% -0.04%	+0.92% -1.31%	+0.95% -1.26%	+0.94% -1.24%
CRYSTAL	+0.0003%	-0.0001%	+0.0002%	+0.001%	±0.0001%	+0.0004%

Signetics 2650 Microprocessor application memos currently available:

- AS50 Serial Input/Output
- AS51 Bit and Byte Testing Procedures
- AS52 General Delay Routines
- AS53 Binary Arithmetic Routines
- AS54 Conversion Routines
- SP50 2650 Evaluation Printed Circuit Board Level System (PC1001)
- SP51 2650 Demo Systems
- SP52 Support Software for use with the NCSS Timesharing System
- SP53 Simulator, Version 1.2
- SP54 Support Software for use with the General Electric Mark III Timesharing System
- SS50 PIPBUG
- SS51 Absolute Object Format (Revision 1)
- MP51 2650 Initialization
- MP52 Low Cost Clock Generator Circuits



a subsidiary of **U.S. Philips Corporation**

Signetics Corporation
811 East Arques Avenue
Sunnyvale, California 94086
Telephone 408/739-7700